

Musical Concepts

MODIFICATION MANUAL

PA - 3B

FOR HAFLER AMPLIFIERS

Thank you for purchasing the Musical Concepts PA-3BB modification. The PA-3B is the result of many years of research. The sound quality you are about to enjoy has been achieved through careful engineering and careful listening evaluation. The PA-3B has the highest quality parts, specifically chosen for their extremely musical qualities. You will enjoy the state-of-the-art performance that until now was only a hidden promise of your amplifier.

ACKNOWLEDGMENT

Musical Concepts would like to thank **Dick Nelson**(*Qualstar Corporation*) for expert assistance with the PA-3B project.

APPLICATION

This modification is designed for the Hafler DH-200/220/500 and XL-280/600 power amplifiers. Dedicated constructors with considerable experience can use the PA-3B to drive a MOSFET output stage using from 2 to 12 power MOSFETS in complementary source follower mode. Such projects should be undertaken only by the most self sufficient types, since Musical Concepts will not offer assistance for custom installations.

DISCLAIMER

Musical Concepts accepts no responsibility for damages, direct or consequential, resulting from this modification. The user solely determines his or her own ability to properly install this product. Musical Concepts accepts no responsibility for personal injury or death resulting from electrical shock hazard.

CIRCUIT DESCRIPTION

The PA-3B is a DC coupled amplifier circuit with a low frequency 'corner' of about 0.10 Hz . It is a Single-Ended, Class-A front-end. The input stage is a Current Sourced Differential Amplifier exhibiting the advantages of symmetry and high input impedance to the driving device. The following LED biased, Single-Ended Cascoded Stage(SECS) voltage amplifier is operated at high current for linearity. This stage is collector coupled to the MOSFET output stage. That is correct, there are only three stages, making the PA-3B an incredibly simple, straightforward design. Of course, the output stage is the tried and proven lateral MOSFETs used in your original Hafler product. Power MOSFETs have nearly 10 times the bandwidth of bipolar power transistors minimizing the phase and bandwidth problems of the output stage. In addition, power MOSFETs are known for their ruggedness under adverse drive conditions.

TOROID POWER TRANSFORMERS

Musical Concepts offers the **TP-200** toroid power transformer with 7 amp(625 watt) capability to replace the standard 4 amp transformer of the DH-200/220(cannot be fitted to the XL-280 unless capacitor arrangement is modified as in the dual-mono version). The **TP-500** is a *pair* of transformers, 500 watts each, used to replace the single transformer of the DH-500/XL-600. When used with twin capacitor power supplies, they are paralleled. They are used separately with the XL-600 or when installed with the DH-500 dual-mono package. These transformers offer amazing improvements in bass solidity, dynamic range, ambience retrieval and speed. There is a velvet-black backdrop to the sound revealing subtle imaging clues.

POWER SUPPLY CAPACITORS

The **LC-200** package consists of two **25,000 mfd** capacitors which replace the standard 10,000 mfd caps used in the Hafler DH-200/220. The **LC-500** is a pair of **39,000 mfd** capacitors for the DH-500, replacing the 20,000 mfd originals. The improvements are greatly improved bass solidity, wider dynamics at any volume level and greater ambience. The sound is more liquid and delicate, yet at the same time revealing of subtleties. 'LC' capacitors are the same physical size as the original caps which reduces installation difficulty. These are the same caps used in our dual-mono conversions.

DUAL MONO CONVERSIONS

Complete dual-mono versions of these amplifiers are available. In the DH-200/220/280, we use our TP-200 transformer which has separate secondary windings. Each winding is separately rectified into a pair of the LC-200 filter caps on each channel, i.e. 100,000 mfd of capacitance. In the DH-500/XL-600 amplifier, we use the TP-500 transformer set which consists of two 500 watt transformers stacked in the space previously occupied by the original transformer. Each transformer feeds a separate rectifier and a pair of 38,000 mfd filter caps for a total of 152,000 mfd of filter capacitance. The rail fuses are mounted directly on the PA-3B, which makes the dual-mono conversion easier.

THE FINISHING TOUCH

You can add Gold-plated binding posts to finish the appearance. The finest package includes the Oxygen-Free Copper, Gold-Plated/Teflon® RCA inputs and Cardas Copper or Gold/Rhodium speaker connectors. These are available in kit or factory installed. All connectors are available separately.

SOLDERING

We recommend that you have some soldering experience before attempting this modification. We remind the veteran that your solder should be **fresh** rosin core type. We provide Kester 63/37 rosin core solder. **Some silver solders that we have evaluated will devastate the sweet delicate sound of the PA-3B. Make sure you are a "solder genius" before substituting for the supplied solder.**

TOOLS

25 to 45 watt soldering iron--not gun, **fresh 63/37 eutectic rosin core solder--provided**
needle nose pliers, diagonal cutting pliers, wire strippers, screwdrivers(philips and flat),
miniature flat blade screwdriver, 1/4 & 3/16 inch nutdrivers (optional),
multimeter with 2 Amp or higher DC Amps scale

INVENTORY

2 - PA-3B circuit boards (stuffed and tested)-- *The PA-3B circuit board layout was designed prior to final tweaking, therefore some parts may be 'missing' from the final board design*

Misc. parts: 1-length of solder(10 ft.), 2-33K 1/2W (Or-Or-Or-Gld) resistors, 2-47K 1W (Yel-Pur-Or-Gld) resistors, 4 - 6800 ohm power resistors (Blue-Gry-Red-Gold), 4 - 2.2 mfd film caps(axial lead), 4 - 0.1 mfd film caps, 2 - 47pf (470J03, 47, etc.) caps, 4 - tie wraps, 3 - 4ft. lengths of 22 ga. wire(3 colors), 2 - 4 ft. lengths of heavy wire (14 GA x 2 colors), 1 - 3 ft. length of 18 Ga. wire, 4 - solder lugs for #10 screw, 2 - Gold-Plated female RCA jacks with isolating washers(2 flat, 2 shouldered), 1 - 5" length of heavy bus wire(solid and uninsulated). **For DH-200 only:** 1 - ground lug tab for #6 screw, **NOTE: Some included parts may not be used in all amps; you may have leftover parts.**

INSTALLATION INSTRUCTIONS

We recommend that you read through the instructions before beginning the modification to determine if you will need the assistance of an experienced friend or professional installation by Musical Concepts. *Musical Concepts installations include considerable performance documentation and a 2 year labor warranty. Kits do not have a labor warranty.*

IMPORTANT: Certain instructions may pertain only to specific amplifiers. These instructions will be preceded by [200], [500/600] etc. Unlabeled instructions are for all amps.

IMPORTANT: Read each step completely before starting work for that instruction.

- 1.() Turn unit off, remove all connecting cords and disconnect AC plug from wall.
- 2.() Remove all screws holding the top cover in place and remove the top cover. A 1/4" nutdriver is the best tool for this on some amps. The screws holding the top cover on the DH-200/220 and XL-280 are between the heatsink fins .
- 3.() Unsolder and remove the input wires from eyelets 1 and 2 at the top of DH-200/220, XL-280 PCB. These eyelets are on the rear of the DH-500/XL-600 PCB.

4.()**[200, 220,280]** Remove the four screws, between the fins, holding the right channel heatsink to the chassis. Let the heatsink rest on an old towel to protect the finish.

5.()**[DH-200]** Each stock RCA input connector is secured by 2 screws. Remove the connectors and attached wires.

6.()**[DH-200 only]** *Read the first sentence of step 7 before starting this step.* Remove the two screws in the top of the power supply capacitor, on the left, as you face the front panel. The filter capacitors are held to the bottom by screws in the feet of the capacitor clamps. Remove the screw nearest to the center of the amp on the same capacitor's foot. Loosen the other screw slightly. 'Twist' the capacitor out of the way and sand off the paint around the hole where you have removed the 'foot' screw. Select the #6 solder lug(ground lug). This is installed where you removed the 'foot' screw, by sandwiching it between the bottom cover and the foot of the clamp. Orient it toward the rear of the amp so it will be convenient to solder wire to it in the following steps. Retighten both of the 'foot' screws securely so that you will have a rock solid ground point. Reinstall the two screws in the top of the capacitor, tighten them securely.

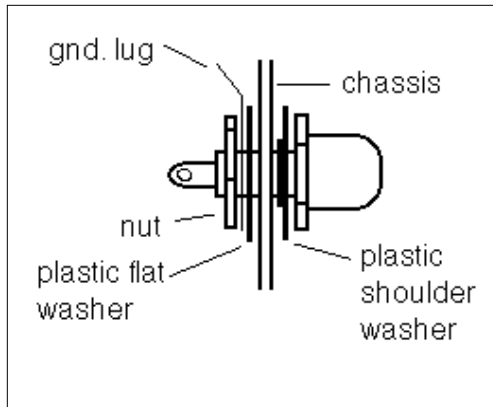

7.()**[DH-200 only]***You may find this step easier if you temporarily remove the power supply caps.* Select the new Gold-Plated, Teflon® insulated RCA jacks and isolating washers (one shouldered, one flat per connector). Presolder the wires to the RCA jacks before they are physically installed into the chassis. The required wire lengths are as follows.: [10" white, 10" and 8" gray for L. Ch., 10" blue, 10" and 8" gray for R. Ch.]. Solder the small gauge white wire to the center lug of the jack for L.Ch. [blue for R. Ch.], and the 2 small gauge gray wires to the separate ground tabs. Next install the shoulder washers onto the RCA jack, as shown. From the outside, install the jack assembly thru the original jack hole with the shouldered insulator against the back panel. On the inside, install the flat insulator, gnd. lug and nut in that order. Tighten securely(Hardware is 12 MM)! Both channels are done the same way. *The shoulder washer must fit inside of the hole to be electrically isolated.* Once installed, twist the each pair of 10" wires at least 2 turns per inch. These will be wired to eyelets 1 and 2 of the PA-3B in a later step. Take the remaining gray wires from each RCA jack and connect to the ground lug installed in step 6. Route these against the bottom of the chassis. They will be soldered in step 9.

8.()**[All amps except XL-280]** Find the center tap of the power transformer secondary. It is one of the wires connected to the existing 'star ground' bus wire between the large filter caps and it goes inside the power transformer housing. Remove it from the star ground and leave the other wires connected. This may take some serious heat, so clip it if you prefer. Select the 5 in. heavy bus wire. Now install this wire to the power supply caps just like the original 'star ground'. Make a slight 'V' shape pointing toward the power transformer(DH-200/220). Point the 'V'(s) toward the front panel in the DH-500/XL-600. This is illustrated in **Fig. B**. The XL-600 requires that this be done with both pair of filter caps - use the #10 lugs. After the wire is formed and crimped around the lugs on each filter cap, solder securely. Faster heating of the solder joint can be accomplished by temporarily loosening the screws connecting the 'star ground' to the large filter caps. This wire is the primary 'star ground'. Now solder the power transformer secondary center tap, which you have just removed, to the center of this new 'primary star ground'. This is the only wire connected on this new bus wire. This removes the charging current gradients from the sensitive secondary star ground, reducing power supply noise.

9.()**[DH-200 only]** Cut a piece of heavy wire about 4.5 inches long. Strip both ends. Solder one end into the ground lug(2 wires are already there), installed in step 6. Crimp the other end around the **rear** wire linking the two large power supply caps, i.e. the secondary star ground. Solder securely near the **center** of the secondary star ground wire. All wires on the secondary star ground should be as close as possible to the center. See Fig. B.

It is time for **DH-500** and **XL-600** owners, to make a choice. Now is the time to decide if you want to remove the power module during the modification. If you have an original DH-500 with PC-10 circuit boards it will probably be necessary to remove the module. Why? Because you will find it impossible to replace the old RCA jacks with the module in place. Also there must be a wire from the 'secondary star ground' to the ground lug between the RCA input jacks(marked "A" in Fig. B). Some later amps and PC-19 amps will already have this wire, earlier amps will not. If you have a DH-500 and you know this ground wire is already in place and you are satisfied with your present RCA jacks, then you can elect to leave the module in the amp. The same can be said for the XL-600.

10.()**[500, 600]** If you would prefer to perform the modification without removing the module, then skip the remainder of this step. There are several wires routed beneath the module, to the fan switch and thermal breakers. **Carefully** desolder(**Keep records for reconnection!**) at the terminal strip end(PC-43 end in XL-600). This will allow you to remove the complete power module from the amp.

11.()**[500,600]** Remove the screws holding the original circuit boards to the module, **save the hardware**, and 'fold back' the boards. This will help you determine which wires can be removed from the original PCB and marked for later installation into the PA-3B. Several wires are still hooked to both circuit boards. NOW, carefully inspect the Figures A, B and C to decide how much labeling you want to

do, as you remove them . As you remove them from the original PCB, mark them with masking tape, etc. to identify where they were connected to the original caps, fuseholders, boards, etc. In other words, the wires connected beneath the module are removed *along with* the module for now, then reconnected to the **same** points. However; it is better to remove the wires for **B+, B-, ground** and **output** right at the original circuit board, **keep records**. Table 1 and Figures A, B and C explain the connections between the PA-3B and your amplifier.

12.()**[500,600]** Remove the 4 screws securing the module base feet to the chassis. Remove the module from the chassis, if this is your plan. If there are still wires connected which prevent this, remove and label them. ***It is your responsibility to keep records.***

13.()**[All except DH-200]** *Since the XL-280 and XL-600 have good quality RCA jacks you might elect to keep the originals.* There is a wire connecting both old RCA jacks to the adjacent ground lug. Clip this wire at the RCA jacks. Now remove both original RCA jacks. Install the two new jacks as shown in step 7, but the twisted pair wires from the RCA jacks to the PA-3B boards have different lengths in different amplifiers(**DH-500/XL-600** = 2 - 10.5" pairs, **XL-280** = 2 - 14" pairs, **DH-220** = 1 - 10 in. pair and 1 - 18" pair). Rewire/solder each jack's ground tab to the chassis ground lug as in the original setup. Make sure the original ground wire, from the star ground between the filter caps, is still connected to the ground lug between the RCA inputs.

NOTE[DH-220 & XL-280]: **Prewire the jacks before installation as outlined in step 7.** It is very hard to get a soldering iron in the limited space around the jacks, once installed. If it is easier for you, temporarily remove the large power supply cap in front of the jacks.

IMPORTANT NOTE! **[for original DH-500 with PC-10 PCB only]** Strip both ends of a 18 gauge(most likely black), 14" wire(1/4" on one end, 1/2" on the other). Insert and crimp the short end to the chassis ground lug between the RCA jacks and solder the other end to the **center** of the 'secondary star ground' connecting the large filter caps. If you have trouble getting enough heat on the star ground wire, temporarily loosen the screws where the wire connects to each filter cap. Run this wire straight forward from the rear and tightly against the chassis bottom; tape to the bottom if you like. Then run straight up to the star ground wire.

IMPORTANT NOTE! **[for XL Series amps only!]** These amps (not all but most) have a Thermistor in the input ground circuit. Remove this device and replace it with a piece of wire. You will find the device on the power supply board of the XL-280, where the star ground is connected to the chassis ground via the chassis ground wire. This is the board on the top of the four large power supply caps. In earlier versions, a foil was cut on the board and the thermistor spanned the cut, i.e. one of it's two leads was soldered to each side of the cut. In later versions, the thermistor was mounted on the bottom(component side) of the board between the rear pair of filter caps. Very early versions did not have the device, so don't change anything. In the XL-600, the device, which looks like a black-matte Nickel or Quarter with lead wires, was connected to a terminal strip near the power supply caps. The upshot of this is that we **don't** want this device between the chassis ground lug and the power supply star ground.

14.()**[DH-200/220/500 only]** Remove the fuses from the dual fuseholders on the floor of the amp. Save these; they will be used on the PA-3B. Since the PA-3B already has the rail fuse holders mounted to the circuit board, you may eliminate clutter by removing the pair of twin fuseholders from the chassis bottom. If you do not wish to remove them, you may simply clip the wires from each end. The wires you are clipping may have been labeled previously. You may transfer a given label to the other wire connected to the opposite end of the same fuseholder. See Fig. B which shows clearly how your amp is wired - you may not feel the need to label wires.

15.()**[DH-200/220/500 only]** The speaker fuse holder has 2 wires attached to it. **Carefully** desolder and remove the wires along with any capacitor mounted to the fuse holder. On the other end clip the wires from the circuit boards. Now you will connect the fuse holders to the 'hot' output posts. If you have decided to eliminate fuses from the signal path, skip the remainder of this step. Select some of the heavy wire provided and connect a wire from each 'hot' output post(from output relay in DH-500) to the appropriate fuseholder for that channel. Connect the wire, leaving a little slack, to the lug in the side of the fuseholder(solder). We recommend that you wrap the stripped wire around the output post's end and solder. This job is not for a 'wimp' soldering iron. The 'end' lug of the fuseholder will be wired in a later step.

16.()**[XL-280/600 only]** The kit has heavier wire for replacement purposes. If you want to use it, now is your chance. Desolder and remove the wires connected from the speaker fuseholders to each circuit board at the fuseholder end. Go back to the last step, read it over and perform the same functional steps for your amplifier. Your goal is **replacing** the wire between the fuseholder(relay board in XL-600) and the output posts.

17.()**[DH-500/XL-600 only]** These amps route the output signal through a relay which provides DC protection. If you wish to remove it from the signal path simply wire around it, i.e. wire the output posts either directly to the PA-3B(eyelet 8) or via the speaker fuseholders. To retain it, connect the heavy wire provided from the relay output to the output posts. Simply trace the wire's path and replace it. **NOTE: Catastrophic failure of the power amp could also destroy the speakers if the relay is removed.**

We recommend that you remove and replace one circuit board at a time, so that you can refer to the connections on the other original circuit board if necessary.

18.() Remove the screws, if you haven't already, holding the right channel PCB to the heatsink. For the DH-200/220/XL-280 you may have to release the heatsink from the chassis to complete this step. Actually, you can start with either board, but we're trying to act organized here! Save this hardware, including the small black washers if present in your amp!

In the next step, you will desolder the wires connecting the original pc board to the output stage, etc. Please keep a record of which eyelet number each wire was connected to on your original Hafler board or exactly where they connected to the chassis. Make a drawing, take notes, or whatever will work for you. It is **your** responsibility to keep records, if you need them. Figures A, B and C clearly shows all needed reconnection information.

19.() 'Fold back' the board and desolder the wires from the eyelets. These are labeled 3 thru 10 on the DH-220/500, 3 thru 12 on XL-280/600 and 3 thru 14 on DH-200. With all wires removed, the board can be removed from the amp.

20.() **Refer to Figure C for this step** Before installing the PA-3B board to the heatsink, it is necessary to make some changes to the MOSFET support circuits. Note the terminal strip(T.S.) located between the MOSFET banks. On most DH-220/500[PC-19]/280/600 there are two capacitors connected to the center lug of the T.S.(ground). Simply remove and replace these with the 0.1 mfd caps as shown - film caps do not have polarity. There may be no caps or one cap connected to the T.S.(ground) on DH-200/500(PC-10). If a cap is present, remove it completely. Then connect and solder the 0.1mfd caps as shown in the illustration--**never short out the lead wires to any other part.** In the DH-200/220/500 there is a cap soldered to one of the MOSFETs. This maroon-colored cap reads 390(391J), 680(681J), possibly 910, etc. Leave these in place. There are two caps labeled 910 on the XL-600 (one on the XL-280) which should be left undisturbed, i.e. no replacement is needed. Add 1- 47pf (labeled $47 \pm X\%$ or 470J03) cap to **one** N-channel(+) MOSFET - make sure the leads of these caps do not touch other points, but keep leads as short as possible. **Do not allow any lead wires to short out to the other parts or wiring.**

21.() Select the PA-3B boards. Make sure that the DC OFFSET pot is set to center and BIAS pot fully clockwise.

22.() Select the value for R12. This is 33K Ohms(Orange-Orange-Orange-Gold) for the DH-200/220 and XL-280 - it is 47K Ohms(Yellow-Purple-Orange-Gold) for the DH-500 and XL-600. Bend the leads appropriately and solder these parts in both PA-3B boards. Install it slightly off the board, about 1/16", for better cooling. Then clip off the remaining lead wires.

23.() Select the fuses from your original dual fuseholders or your original boards if you have the XL-280/600. Look at the elements in each fuse. These are solid, **shiny** metal elements inside clear glass tubes - no springs or ceramic casings please! Each element should be shiny. **If any fuse element is discolored near the center, it is effectively damaged and should not be reused - such fuses won't sound good!!!** If needed, purchase fresh Type AGC, U.L. listed fuses of the proper rating. The ratings are 5 amps(DH-200/220), 7 amps(XL-280) and 10 amps (DH-500/XL-600). **DO NOT EXCEED RATINGS!** These are available at most Radio Shack outlets and car parts shops. Now install these fuses of the proper ratings into the PA-3B fuseholders. The PA-3B is ready for installation, almost.

RECOMMENDED READING FOR XL-280/600: The XL-280/600 has a 'dedicated' front-end power supply. It is 'stereo', i.e. it serves both channels and therefore may produce crosstalk between channels because of it's common connection. On the other hand it has a higher voltage, which ensures that the output stage will 'clip' first, so that the output stage cannot amplify clipping by the front-end. We recommend that you do **not** use the 'front-end' power supply, though the PA-3B is equipped for either choice. Of course, if you have a XL-280/600, you can try it both ways. Your choice will be outlined in later steps and the chart. If you decide not to use the front-end power supply of your XL-280/600, either trim off the wires from their power supply nodes or wrap electrical insulating wire around the ends of the wires.

24.()**[XL-280/600 only]** If you wish to use the XL-280/600 'front-end' power supply, remove the jumper wires from the PA-3B between eyelets E3A and E4A, then between E11A and E12A.

The PA-3B boards have large eyelets which can accommodate up to 12 ga. wire. These holes may seem a bit awkward with the smaller stock wire. As long as you get a good smooth flow of solder from the wire to a good portion of the eyelet foil, your solder joint will work fine even if the hole is not totally covered with solder. Just be careful not to short any unconnected eyelets together.

25.() You will begin by installing and soldering the wires removed from your original boards into the PA-3B boards. Initially connecting the short wires hooked at each end, to the power MOSFETs(i.e. at E5 and E10), will help hold the board steady while you make the other solder joints. Connect the PA-3B according to table below.

Look to Fig. A, B and C and this table to connect your PA-3B boards. **Final version of XL-280 varies - look to Fig. A, B and C**

PA-3B eyelet	purpose of PA-3B connection	connections to PA-3B compared to original Hafler circuit boards			
		DH-200 #	DH-500(PC-10)	DH-220/500(PC-19)	XL-280/600
E3(B+)	1 wire to (+) volts of large power supply caps	equal to 4	equal to (+) wire from P.S. to 3	equal to (+) wire from P.S. to 3	equal to 3
E4	1 wire to B++ (XL-280/600)	no connection	no connection	no connection	* B++ from P.S. of XL-280 or eyelet 10 or 11 of PC-43 in XL-600
E5	1 wire - fused B+ to N-MOSFETs	equal to wire from FETs to 3	equal to wire from FETs to 3	equal to wire from FETs to 3	equal to 4
E6	1 wire - drive to N-FETs	equal to 5	equal to 5	equal to 4	equal to 6
E7(gnd)	ground connection	equal to 6	equal to 6	equal to 7	equal to 8
E8A,B,C (out)	3 wires - 1 to each FET bank - 1 to (+) output post (via fuseholder/relay)	equal to 7,8,9	equal to 7	equal to 6	equal to 7
E9	1 wire - drive to P-FETs	equal to 10	equal to 9	equal to 9	equal to 9
E10	1 wire - fused B- to P-MOSFETs	equal to 14	equal to wire from FETs to 10	equal to wire from FETs to 10	equal to 11
E11	1 wire -to B- - (XL-280/600)	no connection	no connection	no connection	*B- - from P.S. of XL-280 or eyelet 6 or 7 of PC-43 in XL-600
E12(B-)	1 wire to (-) volts of large power supply caps	equal to 13	equal to (-) wire from P.S. to 10	equal to (-) wire from P.S. to 10	equal to 12

PS = power supply, PC-43 = relay PCB in XL-600, N-FETs = N-Channel MOSFETs connected to (+) rail voltage, P-FETs = P-Channel MOSFETs connected to (-) rail voltage, *This entry would read 'no connection' if you have decided **not** to use the dedicated 'front-end' power supply of the XL-280/600. # On the original DH-200 PC-6 boards, eyelets 3 & 4 are on the same foil, likewise for 7, 8 and 9, then 13 and 14; this is easy to see in the original manual.

Make an inspection of the circuit board and wiring. Remove excess solder flux with a small screwdriver or knife blade. **CAREFULLY INSPECT THE WIRES CONNECTED TO THE BOARD. SOME OF THESE MAY HAVE BECOME FRAYED AND WEAKENED BY FLEXING. IF NEEDED, RESTRIP THESE AND RESOLDER IN PLACE.** We frequently repair amps with simple broken wiring. Amps with frayed wiring definitely do not sound as good as carefully wired units. **CHECK THE PA-3B FOR SOLDER BRIDGES OR SPLASHES. THE SMALLEST SOLDER BRIDGE/SPLASH CAN SPELL DISASTER.**

26.() Select the mounting hardware for the original PCB and fasten the PA-3B to the heatsink.

27.() [DH-200/220/280] Using the original mounting hardware remount the heatsink to the chassis. **Don't smash wires beneath heatsink!** Reconnect the input jacks to the PA-3B. Remember eyelet E1 on PA-3B is for the hot wire of the input signal, i.e. connect to the center pin of the RCA jack, while eyelet E2 is for the ground part of the connection.

28.() Repeat steps 18 to 27 for the other channel.

HAVE YOU?... Connected eyelet E8 of the PA-3B to the proper speaker fuseholder, relay(DH-500/XL-600) or output post?
Connected all wires to proper eyelets #E3 to #E13 on PA-3B? - Double check for the 2nd time!!!

IF YOU... Installed the CORRECT value fuse in the F1 and F2 positions on the PA-3B.
have any doubts about your installation, do not proceed!!! Get clarification!!! --
from Musical Concepts 636-447-0040, 9am - 5pm daily(mon. - fri.)

29.() [DH-500 ONLY]: The relay circuit board must receive (+) and (-) voltages from the power supply. This was previously picked up from the dual fuseholder nearest to the relay board. Now the voltage pickup must come from another source. Remove the original wires connected to eyelets 4 and 6 of the relay PC board(PC-9). Select 2 - 15" different colored wires(light gauge) and solder one at eyelet 4, another at eyelet 6. Now twist these together with the wire connected to eyelet 5 until you get near the bridge rectifier, then bring the two new wires to the bridge. The bridge is the square block with four posts near the single fuseholder. Solder the wire from PC-9 eyelet 4 to the rectifier post at the left front as you face the front panel, i.e. the negative rail voltage. Solder the wire from PC-9 eyelet 6 to the positive rail voltage on the bridge, i.e. the post at the **opposite** corner of the rectifier. If you have a dual-mono converted amp use the connection method described on the nearest rectifier. If your amp was not wired according to the book, just remember PC-9 eyelet 4 must receive negative rail voltage and PC-6 eyelet 6 must receive the positive rail voltage.

30.() [DH-500/XL-600] Reinstall module to the amplifier chassis. **Don't smash wires beneath module 'feet' when reinstalling!** Reconnect it according to your notes and with reference to the table, plus Fig. A, B and C.. Connect the input jack wiring to the PA-3B. Remember eyelet E1 on PA-3B is for the hot wire of the input signal, i.e. connect to the center pin of the RCA jack, while eyelet E2 is for the ground part of the input pair. These wires must be twisted throughout their length.

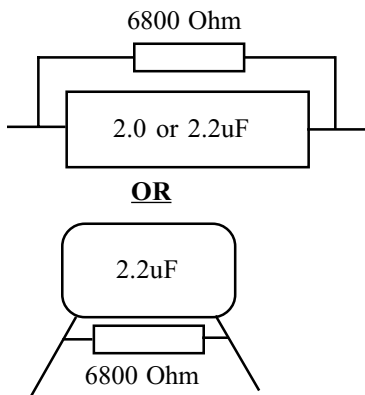

31.() Note the large 'can' power supply caps, two in stock DH-200/220/500, four in XL-280/600 or you may have four in a dual-mono converted amp. In this step you are to wire 1 - 2.2 mfd cap paralleled with 1 - 6800 Ohm, 2 Watt resistor(Blue-Gray-Red-Gold)(see illustration). You have parts to make 4 pairs. Now connect these in parallel to each of these large power supply caps. Imagine this as a tandem connection, piggyback etc., i.e. connect one lead of the cap/resistor to either (+) or (-) of a large filter cap and the other lead to the remaining terminal. The XL-280 has a power supply circuit board, so cut the leads to an appropriate length and solder the cap/resistor to the side of the board. **Make sure the part itself and lead wires clear the top cover!** Repeat for both or all four caps. If the amp already has capacitors installed at this circuit location(from a previous mod, etc.), you may use these as additional parallel bypasses. Those with only two power supply caps may parallel two 2.2 mfd caps and use this combo as the bypass - still using only 1 resistor per large power supply cap. Solder lugs are provided. You could use them to add additional solder points to the P.S. caps in most of the amps.

32.() Select the four tie wraps. They may be used to improve the appearance of the wiring. The wires going to the 'star ground' should be tightly clasped as they rise from the floor of the amp to the connection point. Multiple wires connected to the other capacitor terminals may also be secured. Other wiring should be routed close to the bottom cover where possible.

33.() Turn the amplifier upside down on the tabletop and rap the bottom sharply, then shake. This will loosen any wire or residue in the amp so it can fall out harmlessly. You avoid embarrassing problems in the near future.

IMPORTANT!!! ALWAYS OBSERVE EXTREME CAUTION WHEN AC POWER IS APPLIED TO THE AMPLIFIER, DURING THE FOLLOWING TEST ROUTINES!!!

Make sure that DC OFFSET pot VR1 is set to center position. Likewise set BIAS pot VR2 fully clockwise.

VARIAC START-UP PROCEDURE: If you have access to a Variac or can borrow one, use it. Ramp the voltage up slowly and observe the current flow (SEE 'RE-BIASING' BELOW). If you have no current flow (with bias pot R10 turned 3 o'clock) or an excessively high current at 15% of line voltage, there is a problem with the installation or the amp as a whole. Fix the problem! **PREFERRED METHOD:** If you have a scope and generator, inject a 1kHz low amplitude sine wave into the amplifier and observe the output waveform (the bias pot can be fully clockwise for this test). A clear waveform is evident with as little as 15% of line voltage applied via the Variac. As you turn up the Variac you will see some DC shift on your scope before the waveform appears. This is normal. Remember, with the DH-500/XL-600, the relay does not connect the amplifier to the speaker until the amplifier is completely turned-on, so you can connect your Scope directly to eyelet 8 of the PA-3B. If you observe a "normal" sine wave you can assume that the mod is installed correctly. These methods give assurance that there is no problem with the installation, before full AC power is applied, an undeniable advantage.

RE-BIASING PROCEDURE: Turn the screwdriver adjustable potentiometer '**BIAS, VR2**' on each PA-3B fully clockwise. Now turn it counterclockwise 1/4 turn or as you are looking down on the pot put it at 3 o'clock position. The four fuses on the PA-3Bs supply current to the output stage. **Temporarily remove both fuses from one channel.** This is done in case you have made a wiring error common to both channels. Then remove the positive voltage fuse(F1) from the other channel. **NOTE:** If you have two voltmeters, you can adjust both channels at the same time. Clip the positive lead of a voltmeter(either lead with a digital meter) to the fuse terminal closest to the 'end' of the board; clip the other lead of the meter to the remaining terminal. Make sure the meter can read 2 amps DC on the scale you've selected and **remember most meters need a different input connection to read amps as compared to volts.** **Now with both leads SOLIDLY connected(do not use "probes", but something like alligator clips), plug in and turn on the amp. NO INPUTS OR OUTPUTS CONNECTED PLEASE!** Turn the adjustable pot counterclockwise from above to set bias current to 270 milliamps for DH-200/220, 330ma for XL-280 or from rear(DH-500/XL-600) to increase the current to about 330 milliamps(ma.). Reset after about 5 minutes of operation. Turn the amp off and wait for it to discharge, i.e. it will read close to 0 ma. shortly after shutoff. Unplug it temporarily. Remove the meter leads and install the proper value fuse in the channel just tested. Repeat re-biasing for other channel. **OPTION:** If you put the highest value on performance, in other words, a smoother and clearer sound, you may bias the amplifier "deeper" into Class A. Set the bias for the DH-200/220 to 430ma, the DH-500/XL280 to 630ma or the XL-600 to 800ma. Be assured that your amp will run much hotter. You may not like that and desire to turn it back down. You may adjust it 'midway' and get a bit smoother sound without extreme heat. You might run the first setting in Summer and the 'hot' setting in Winter. Hey, it's your thing. It is likely that the DH-500 and XL-600 fans will run at higher speed, i.e. it will be noisier. This might be unacceptable for you. At any rate, do not adjust above the highest ratings given here as the output devices will begin to 'self current limit' at seriously elevated temperatures.

34.() ***Set your DC offset voltage!*** Turn the amp on. Do not connect an input signal or speakers. Connect a voltmeter between one of the "star ground" and the Left channel speaker 'hot'. The idea is to detect any DC voltage on the speaker outputs, then adjust it to near 0 Volts. If you detect a high DC voltage (5 or more volts) then the amplifier has a problem. You will probably detect less than 125 millivolts, i.e. 0.125 volts, when the amp is operating properly. Using a small screwdriver, adjust the '**Offset Pot**' **VR1** for the lowest voltage at the speaker output. This is not an exact thing, as you will see some voltage drift over time in the output. This is normal. Adjust the voltage to about +10mV(millivolts) after a short warm-up period. This will be adequate. Repeat for other channel. **IF 1.5 VOLTS OR MORE ARE PRESENT AT THE SPEAKER OUTPUT TERMINALS, YOU MUST RESOLVE THE OPERATIONAL PROBLEM BEFORE CONNECTING SPEAKERS. TOO MUCH DC OFFSET MAY DAMAGE YOUR SPEAKER.**

35.() Select the top cover and reinstall.

36.() Select the sticker "Musical Concepts modifications" and apply under 'Hafler' on the front panel.

37.() Select the product identification sticker with model no. etc. and install on the rear or bottom of the amp. Do not obstruct the air flow holes if installed on the bottom.

Congratulations! You have finished the PA-3B modification. Please let us know your thoughts on your registration card.

WARRANTY: The parts used in Musical Concepts modifications are warranted for a period of 2 years from the date of original sale to the original purchaser. Parts clearly damaged by the installer are not warranted. ***Labor is not covered on user installed modifications.***

TECHNICAL INFORMATION: The following information is provided more as an advisory for troubleshooting or performance confirmation, than as "hard" specs.

DISTORTION(THD): less than 0.09%(1khz, 10 watts) typically less than 0.05%.

PERFORMANCE OPTIONS

Musical Concepts tests numerous parts for sonic invisibility! We do not recommend any parts substitutions in this kit. Each component has been carefully selected. If you contemplate using parts with more hype factor, please get thoroughly acquainted with the sound before changing to the supposedly infallible substitute. Compare carefully, don't ass-u-me anything! Our parts come as close to the mythical straight wire as possible. Some of the most hyped parts are lauded for their most outrageous colorations, i.e. parts are often admired for their character. We like parts without character.

EXTRA GAIN: It is possible to increase the gain of the PA-3B by 3 or 6 DB. This is done by changing only one feedback resistor per channel. Extra gain can be useful if you are using a passive control center or a CD player without preamp. The original value of R17 is 90.9 ohms; changing to 47.5 ohms yields approximately 6db gain increase; using 68.1 ohms gives about 3db increase. Higher gains are not recommended, due to noise considerations.

FUSES: The stock speaker fuses are rated at 2 amps(DH-200/DH-220/XL-280) and 5 amps(DH-500/XL-600) with most units, with 5 or 10 amp sizes optional if you have 4 ohm speakers. 5 and 10 amp sizes give better sound. Since this fuse rating offers little or no speaker protection, you may wish to eliminate the speaker fuses. Short the two lugs on each speaker fuse terminal together using at least 18 Ga. wire. Better yet, simply bypass the fuse holder with a wire connected directly from the PA-3B(E8) to the output post. **WARNING!-- UNDER SOME CIRCUMSTANCES THIS COULD LEAD TO CATASTROPHIC SPEAKER FAILURE!**

WIRING: While the stock wiring in Hafler amps is 'adequate', some of you will want to use heavier wiring. Musical Concepts rewires amps as a special added service. The obvious places for use of such wire is in the speaker outputs, the power supply wiring and the ground system. The twisted wires used for the input signal are quite effective. Proceed carefully, many "Special Audiophile Grade" wires sound appallingly inferior to the standard input pair. One advantage of the PA-3B is it's 12 ga. wire holes where high current may be encountered.

Figure A

PA-3B PART AND CONNECTION LAYOUT

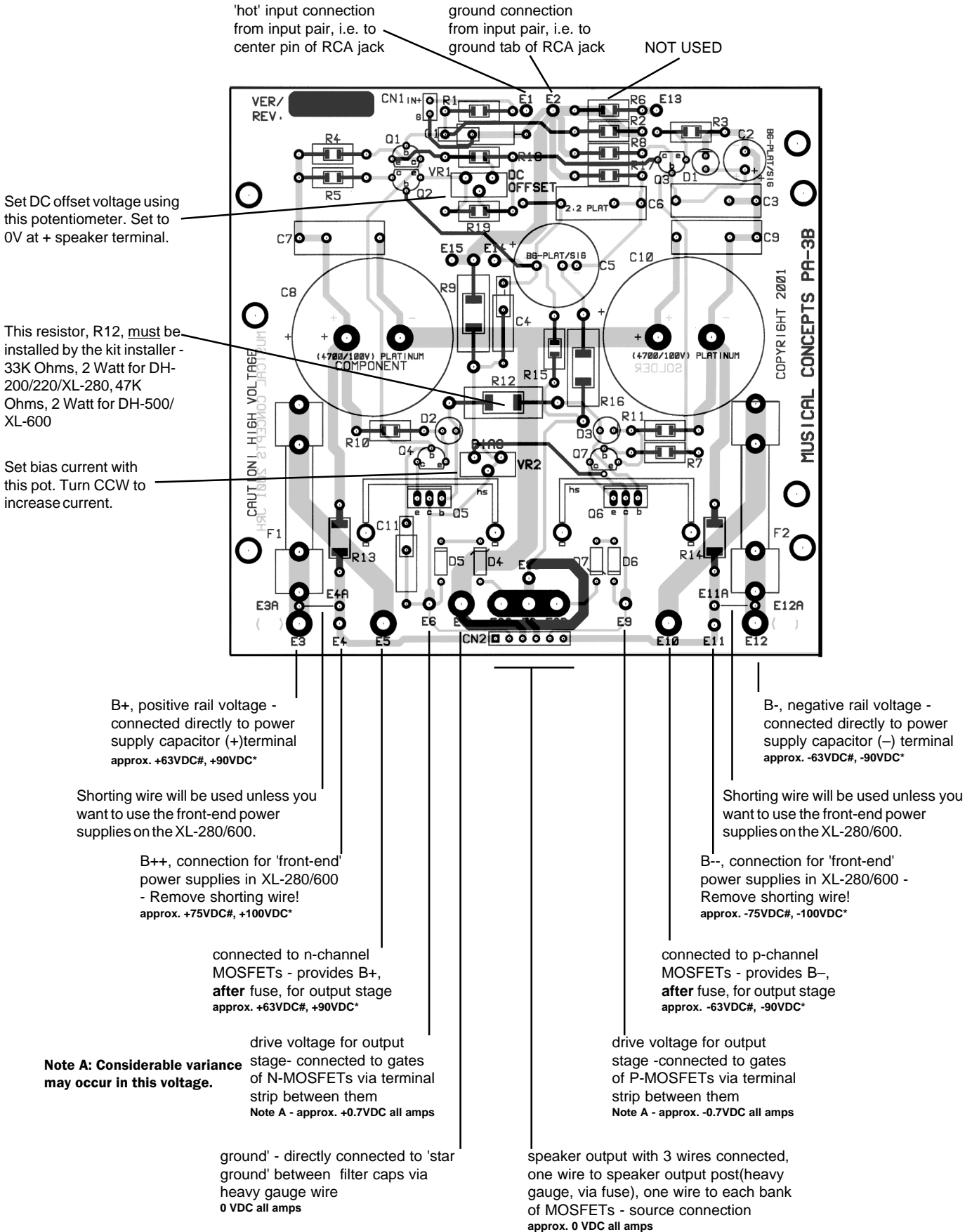

voltages in DH-200/220/280
 * voltages in DH-500/XL-600

NOTE: Wire colors shown do not indicate colors to be used - they are only for clarity.

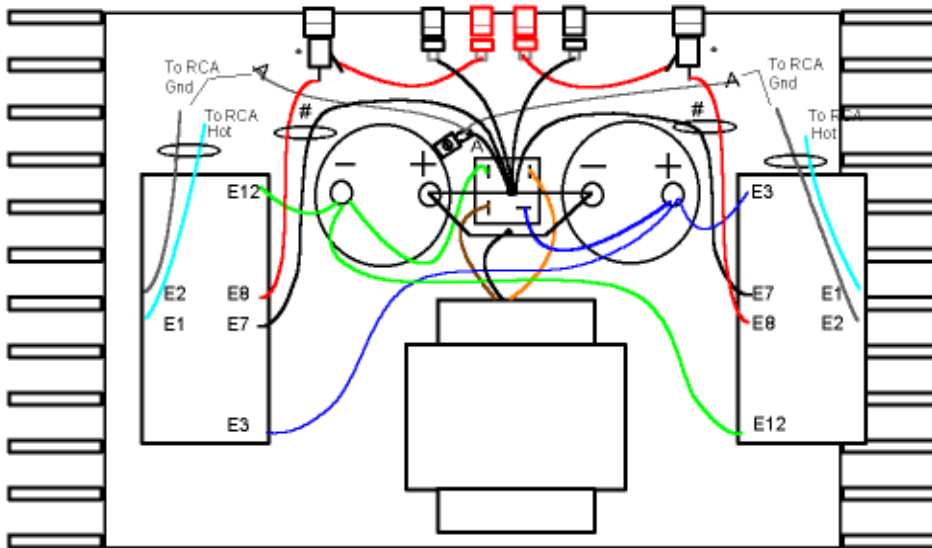

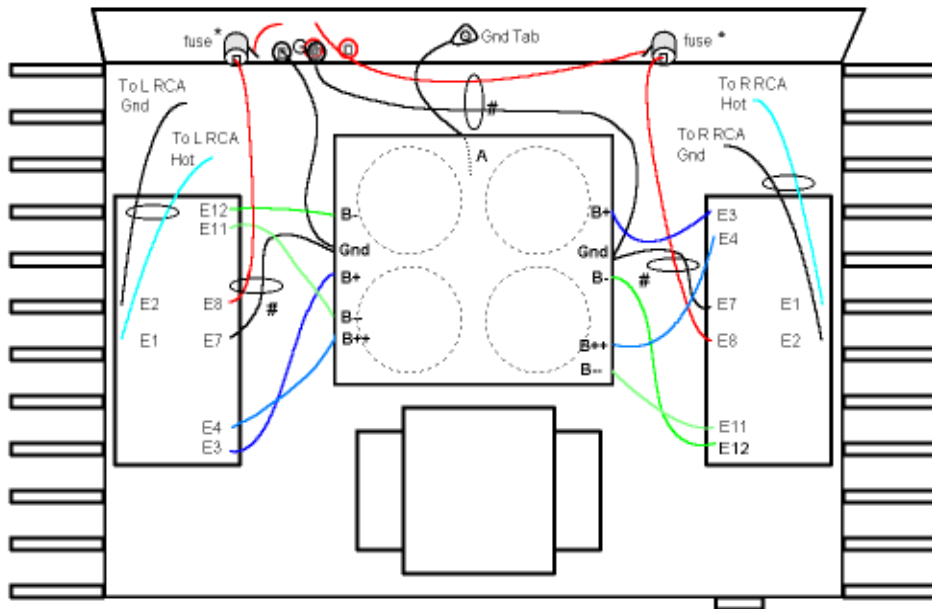

Fig. B
DH-200/220 BASIC LAYOUT

LEGEND

-  - encircled wires are twisted
- # - keep this pair against chassis
- * - wire 'past' to eliminate fuse
- A - 3 wires/lug used only on DH-200



XL-280 BASIC LAYOUT

LEGEND

-  - encircled wires are twisted
- # - keep this pair against chassis
- * - wire 'past' to bypass fuse
- A - Gnd wire to lug at RCAs

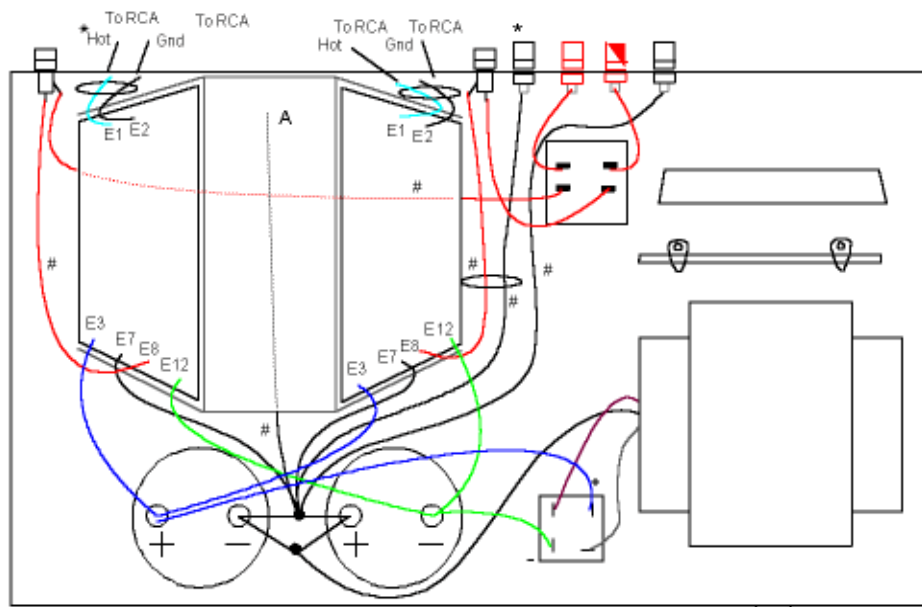

DH-500 BASIC LAYOUT

LEGEND

-  - encircled wires are twisted
- # - keep wires(s) against chassis
- * - wire 'past' to eliminate fuse
- A - wire to Gnd. lug at RCAs

Finished view after modification
Shows wiring to foil side of PA-3

- existing resistors
* - twist these wires

XL-600 similar, but has 8 MOSFETS

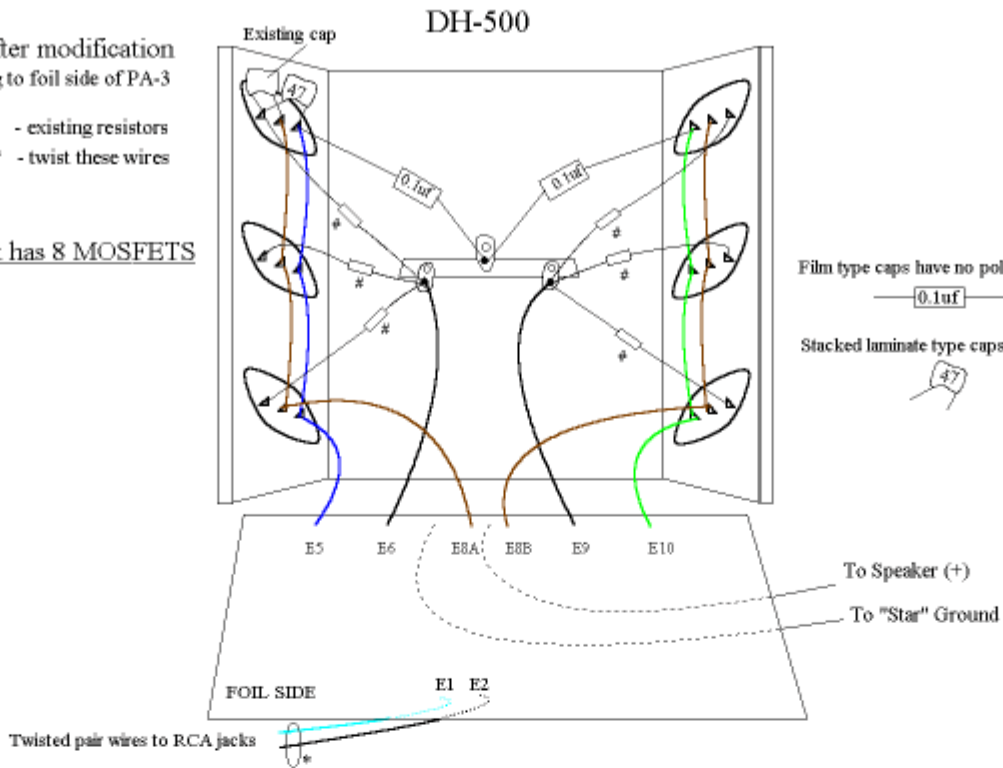

NOTE: Wire colors shown do not represent actual colors used

Finished view after modification
Shows wiring to foil side of PA-3

- existing resistors
* - twist these wires

XL-280 similar, but has 6 MOSFETS

